



# FSW EASY Safe – Types and functions

**FSW toughened glass folding walls featuring door rails top and bottom and a roller carrier at the end of each second panel.**

FSW folding sliding walls are suitable for linear configurations. With an FSW EASY Safe assembly, you can have either two or four panels (a basic panel and 1 or 3 folding panels) linked together. Where two counter-running (bi-parting) assemblies are installed, it is possible to create frontages with up to eight FSW panels.

As the panels are visually compatible with the HSW EASY Safe pivoting/sliding panels, and both systems use the same track design, shop/store frontages or similar transparent partition systems can be made up of these two different types, with the FSW assembly at the free end or supplemented by a single- or double-action HSW end panel (types 4+5). FSW systems can be designed for either opening direction.

## Example: Design with 2 x 2 panels (type 1c), bi-parting

- 01**  
Track rail
- 02**  
Upper locking bolt
- 03**  
Roller carrier
- 04**  
Face mounted slide bolt
- 05**  
Upper pivot bearing of the basic panel
- 06**  
Basic panel
- 07**  
Folding panel

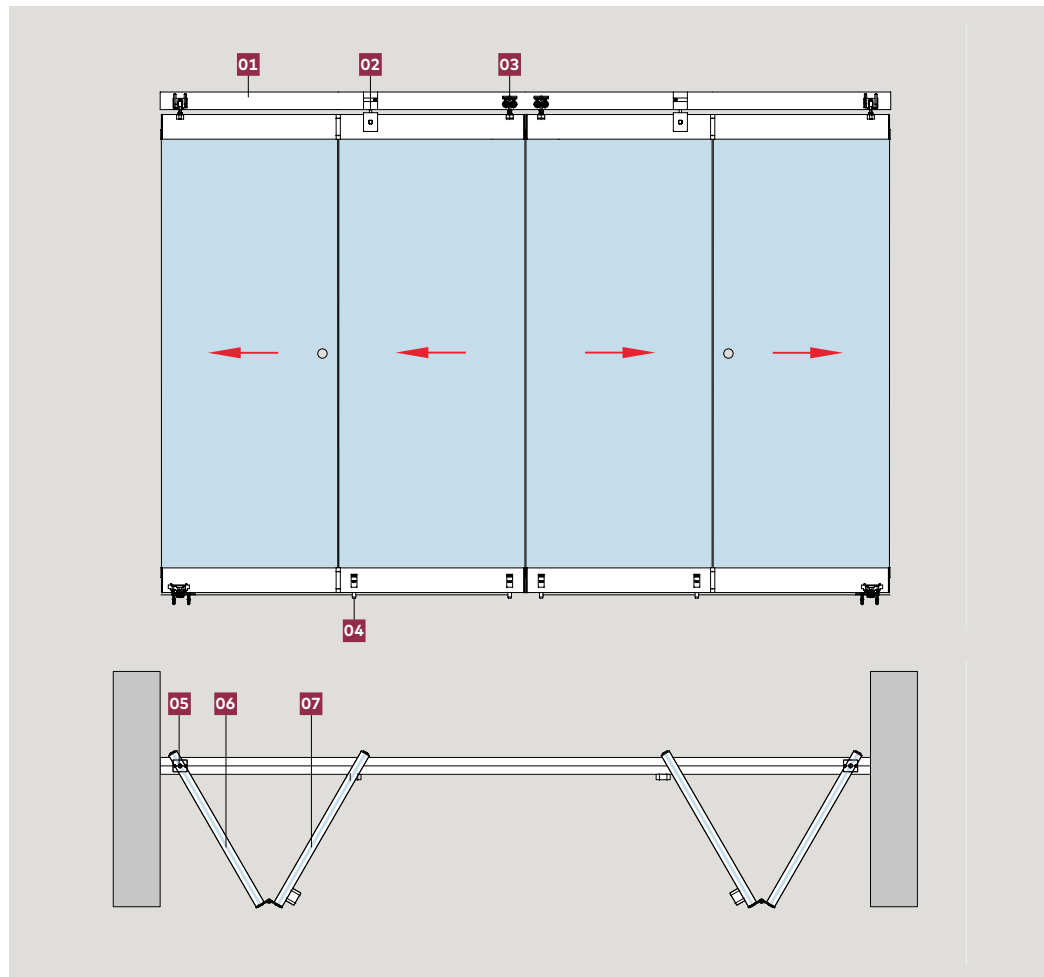

Max. panel sizes and weights	Basic panel with top pivot and floor pivot	Folding panel with roller carrier and lock bolts top and bottom	Folding panel with roller carrier and lock bolts top and bottom	Basic panel with roller carrier and lock bolts top and bottom
<b>Max. assembly height</b>	3000 mm	3000 mm	3000 mm	3000 mm
<b>Max. panel width</b>	1100 mm	1100 mm	1100 mm	1100 mm
<b>Max. panel weight</b>	80 kg	80 kg	80 kg	80 kg

The standard thicknesses are 10/12 mm toughened safety glass (TSG). Other thicknesses and glazing with laminated safety glass (LSG) available on request.

# System components

## Basic panel

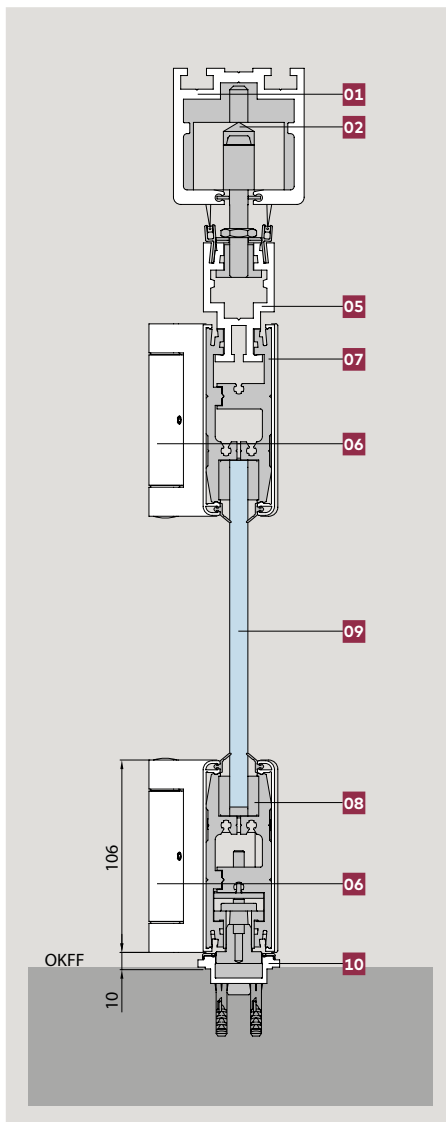

## Folding panel

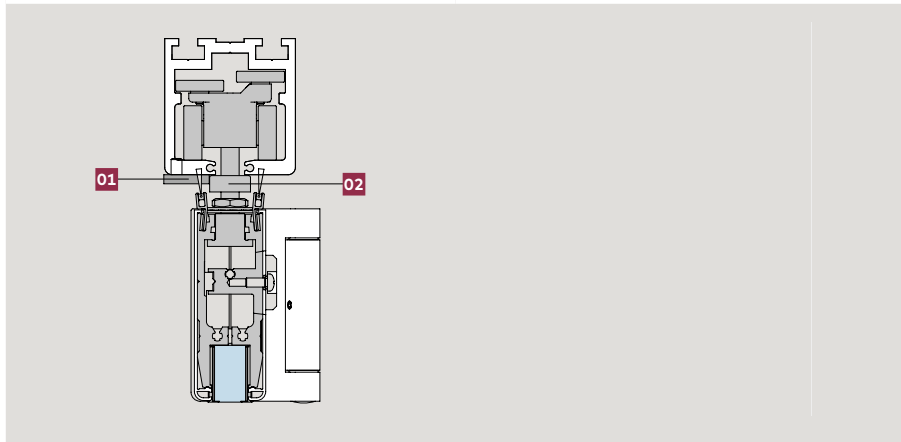
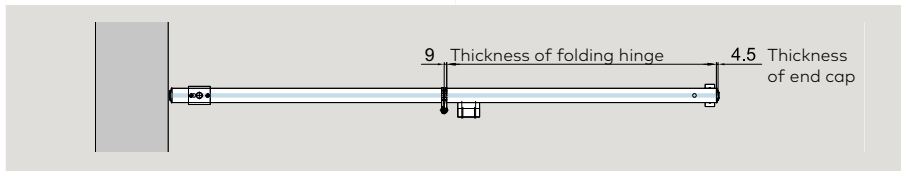
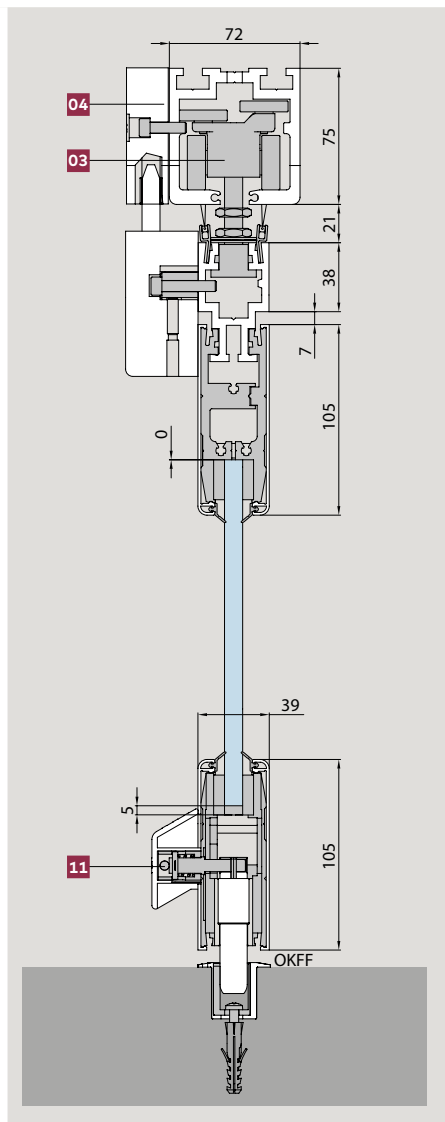

The FSW EASY Safe assembly consists of the following basic components:

- 01** Track rail (fixed to the substructure)
- 02** Upper pivot bearing
- 03** Roller carrier
- 04** Upper locking bolt
- 05** Carrier profile  
Design without a carrier profile also available – see drawing below
- 06** Folding hinge
- 07** Top door rail (consisting of basic profile and covers with lip seal)
- 08** Bottom door rail (consisting of basic profile and covers with lip seal)
- 09** Toughened safety glass, or LSG of TSG (when using LSG we recommend the Clamp&Glue technology)
- 10** Floor pivot bearing
- 11** Face mounted slide bolt

- 01** Contact plate
- 02** Roller carrier with stop device

# Layout variants

## Type 1

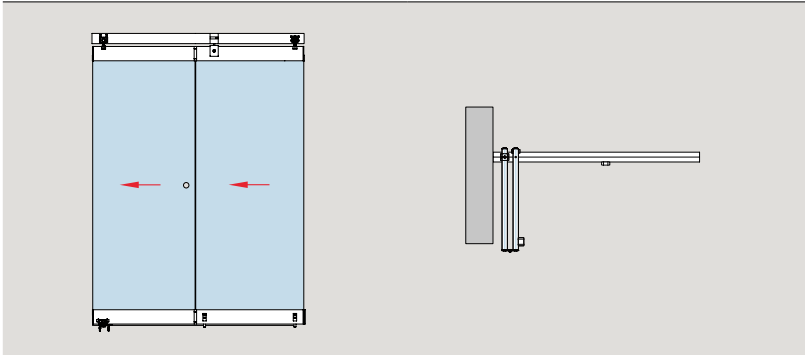

### Classification Product description

- 1a** 2 panels left, as illustrated
- 1b** 2 panels right, invers
- 1c** 4 panels (2 panels left and 2 panels right), bi-parting

## Type 2

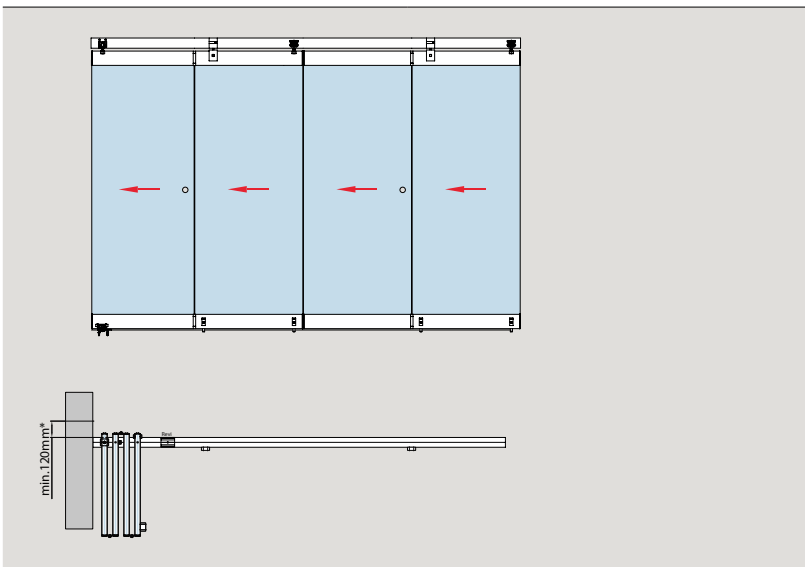

### Classification Product description

- 2a** 4 panels left, as illustrated
- 2b** 4 panels right, invers
- 2c** 8 panels (2 panels left and 4 panels right), bi-parting

## Type 3

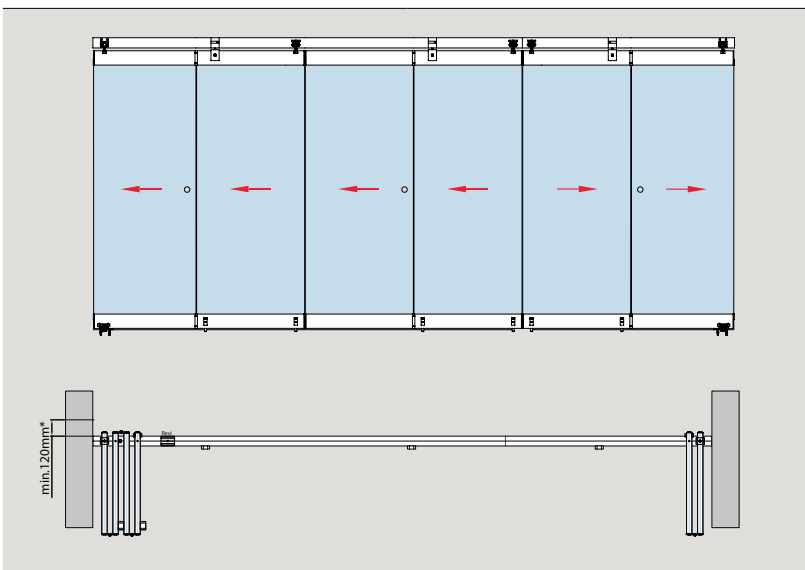

### Classification Product description

- 3a** 6 panels left, as illustrated  
(4 panels left and 2 panels right)
- 3b** 6 panels left, invers  
(2 panels left and 4 panels right)
- 3c** 8 panels  
(4 panels left and 4 panels right)

\* Minimum structural clearance (e.g. balustrade, railings etc.)

**Type 4**

**Classification Product description**

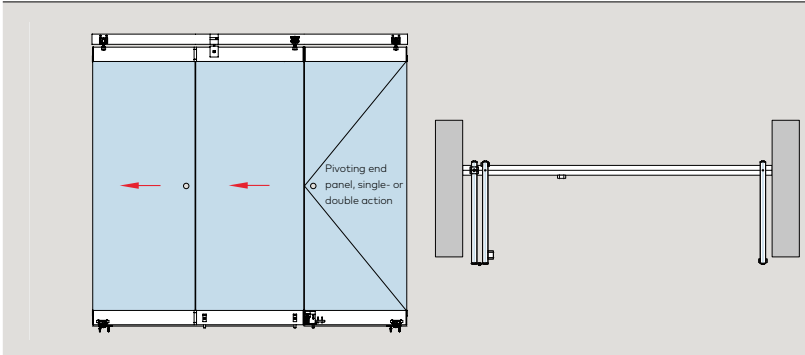

**4a** 2 panels left and 1 pivoting end panel, single- or double action, right (as illustrated)

**4b** 2 panels right and 1 single- action or double-action end panel left (invers)

**Type 5**

**Classification Product description**

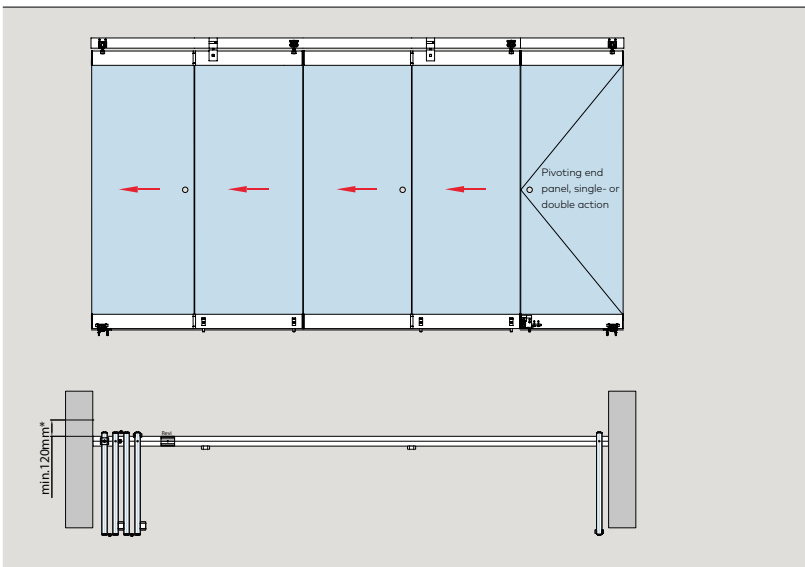

**5a** 4 panels right and 1 pivoting end panel, single- or double action, right (as illustrated)

**5b** 4 panels right and 1 pivoting end panel, single- or double action, left (invers)

\* Minimum structural clearance (e.g. balustrade, railings etc.)

# FSW EASY Safe C – Types and functions

## Toughened glass folding partitions with door rails top and bottom roller carrier at panel centre

The FSW EASY Safe C is adaptable to large spans. An assembly comprises a basic panel, up to 6 folding centre panels and a folding pivoting panel which, when the system is closed, can be used for access (alternatively, a non-attached single or double action end panel can be used). The number of panels therefore ranges between 3 and 8. As the roller carriers are centrally arranged on the centre panels, the basic

panel must be designed as a half-width unit (plus pivot offset of 65 mm). The pivoting access panel can be of either basic panel or centre panel width. The slightly offset hinges mean that the panels can be folded into particularly compact stacks, with high stability also ensured. Available as standard for glass thicknesses of 10 or 12 mm. Other glass thicknesses and models with laminated safety glass also available on request. Please indicate your requirements when ordering!

### Example: Partition type C2 (symmetrical with narrow pivoting access panel)

- 01**  
Pivot bearing top and bottom
- 02**  
Basic panel
- 03**  
Track rail
- 04**  
Roller carrier
- 05 + 07**  
Flap panel unit
- 06**  
Folding hinge

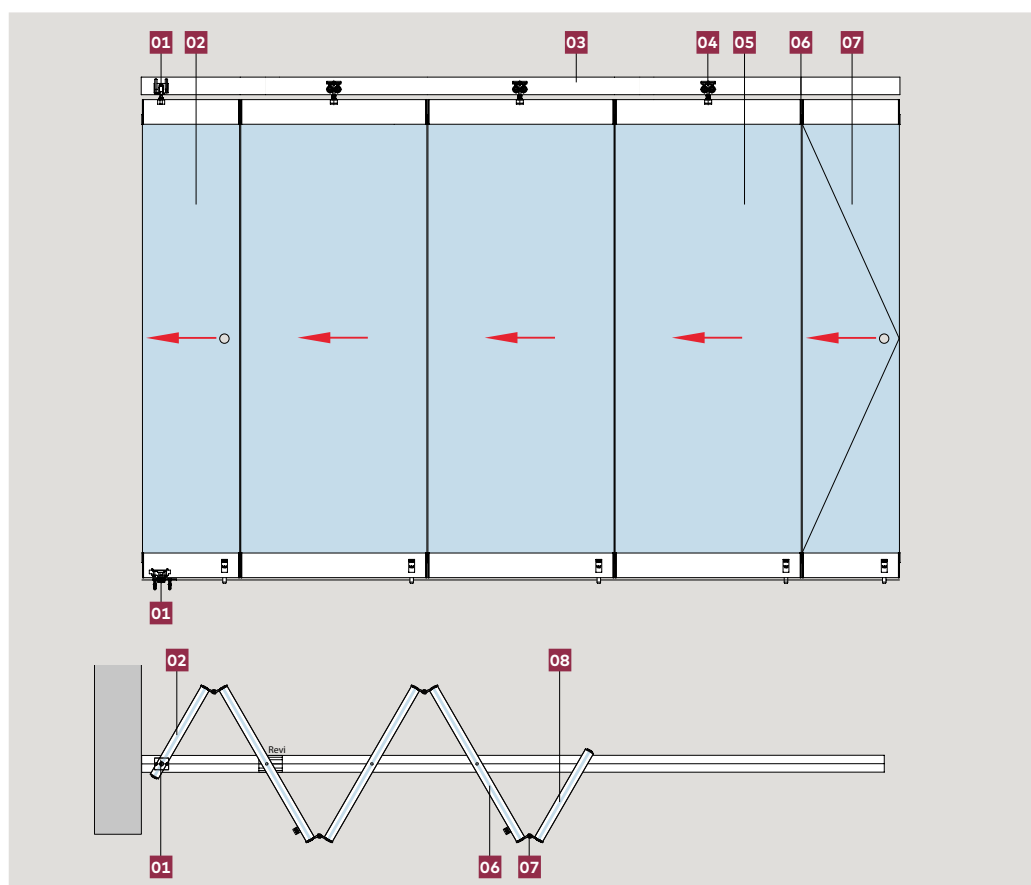

Max. panel sizes and weights	Basic panel with top pivot and floor pivot	Centre panel with roller carrier and lock bolts top and bottom	Centre panel with roller carrier and lock bolts top and bottom	Flap panel unit
Max. assembly height	3000 mm	3000 mm	3000 mm	3000 mm
Max. panel width	½ panel width + 65mm	1100 mm	1100 mm	1100 mm
Max. panel weight	80 kg	80 kg	80 kg	80 kg

The standard thicknesses are 10/12 mm toughened safety glass (TSG). Other thicknesses and glazing with laminated safety glass (LSG) available on request.

# System components

## Folding panel with bolt

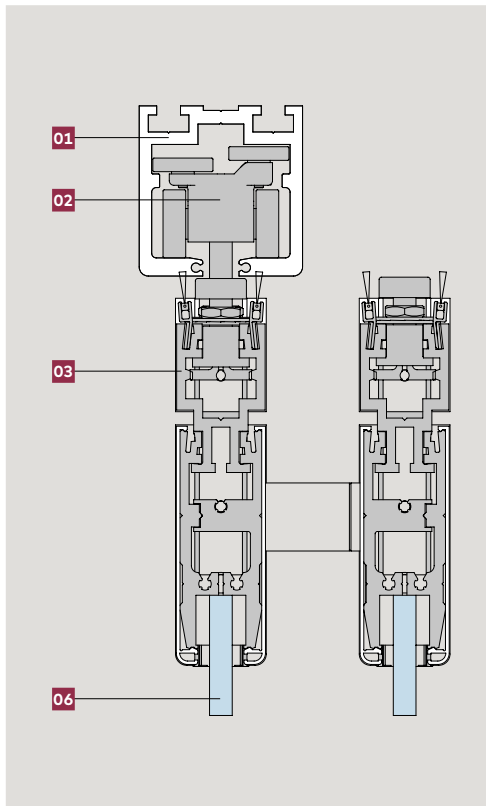

## Magnetic door holders top and bottom

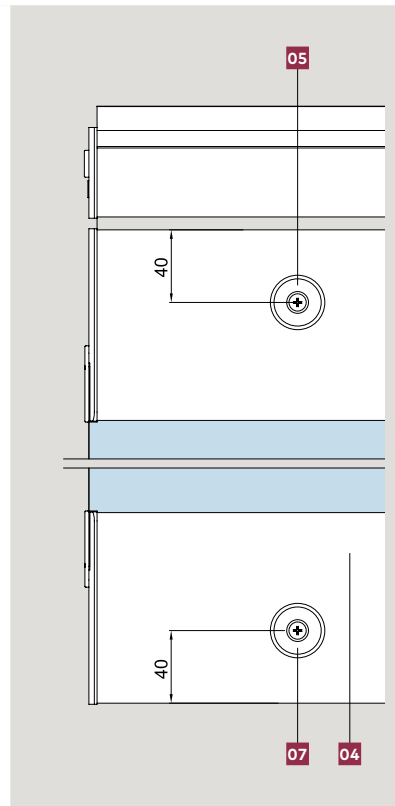

The FSW EASY Safe C system consists of the following basic components:

- 01** Track rail (fixed to the substructure)
- 02** Roller carrier
- 03** Carrier profile  
Top door rail also available in a design without the carrier profile – see drawing below.
- 04** Bottom door rail consisting of basic profile and covers with lip seal.
- 05** Magnetic holder top
- 06** Toughened safety glass, or LSG of TSG (when using LSG we recommend the Clamp&Glue technology)
- 07** Magnetic holder bottom

## Bottom hinge

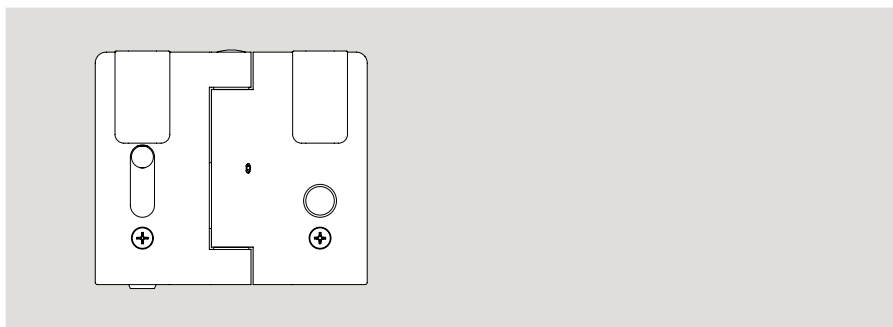

## End mounted slide bolt at the bottom between both panels of the flap panel unit

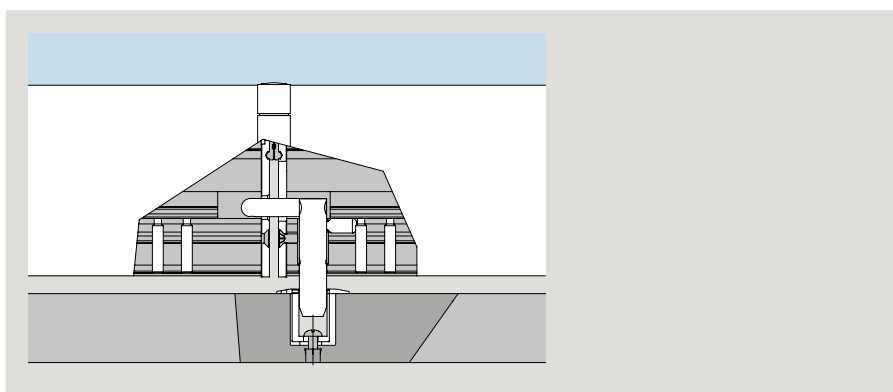

# Layout variants

## Type C1

## Product description

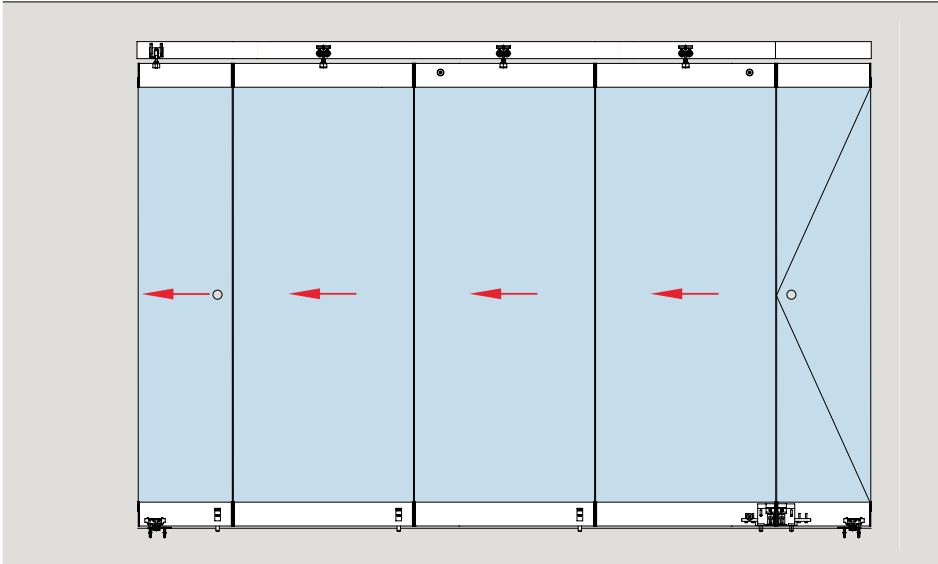

- 1 pivoting end panel, single-action, as access (here in narrow design for reasons of symmetry)
- 1-6 centre panels
- 1 basic panel (narrow)

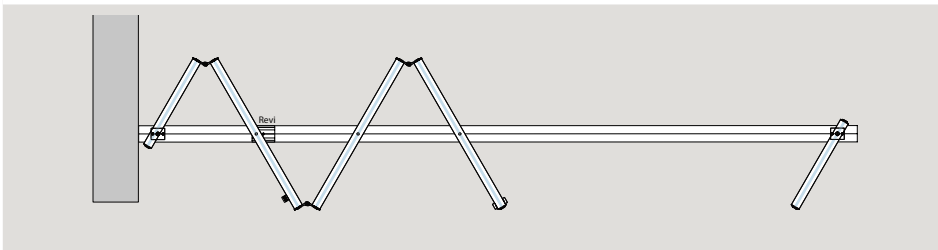

## Type C2

## Product description

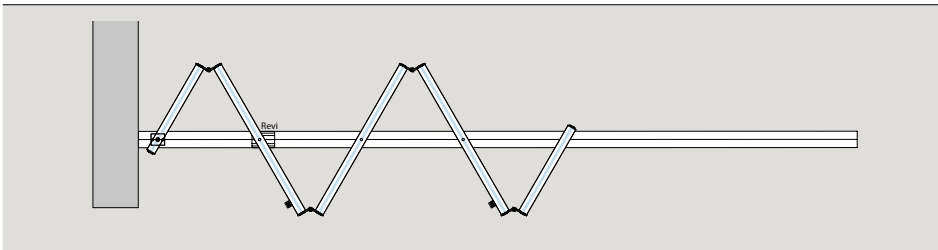

- 1 pivoting access panel (here in narrow design for reasons of symmetry)
- 1-6 centre panels
- 1 basic panel (narrow)



**Type C3**

**Product description**

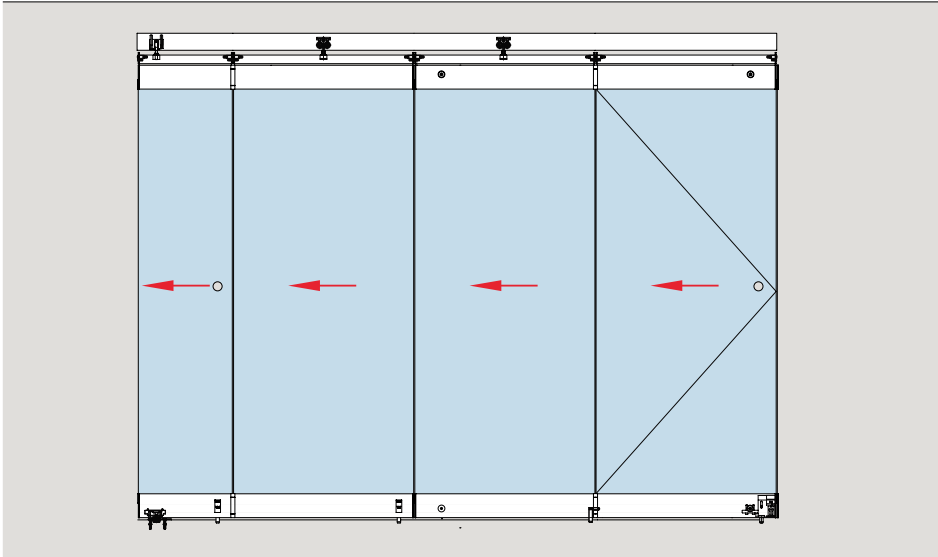

- 1 basic panel (narrow)
- 1-5 centre panels
- 1 dual panel assembly

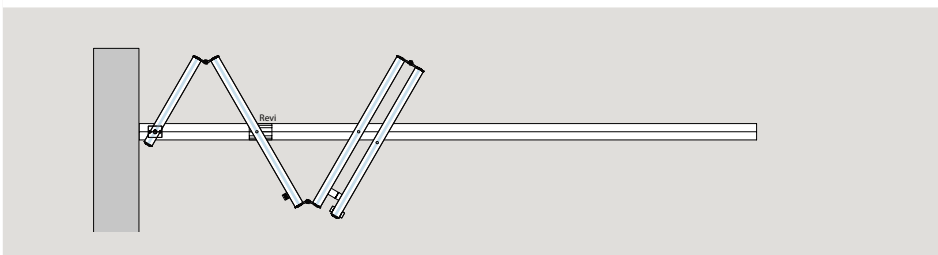

**Type C3, dual assembly (bi-parting)**

**Product description**

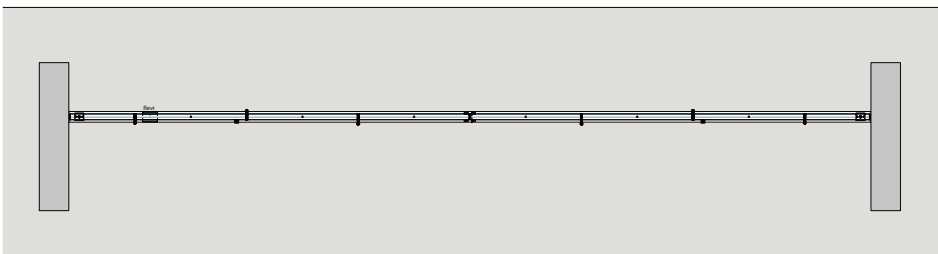

- Left:**
- 1 basic panel (narrow)
  - 1-5 centre panels
  - 1 dual panel assembly

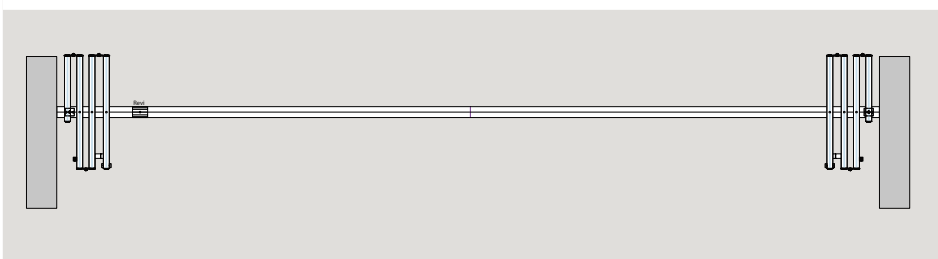

- Right:**
- 1 basic panel (narrow)
  - 1-5 centre panels
  - 1 dual panel assembly

# FSW EASY Safe Cplus – Types and functions

## Access with convenience – the plus you get with the FSW EASY Safe Cplus

Based on the design of the FSW EASY Safe Cplus, the model variant FSW EASY Safe Cplus offers the possibility of including a flap panel as a fully fledged access door when the system is otherwise closed – with all the automatic closing convenience which the dormakaba TS 93 G cam-action door closer can offer.

The special bottom lock bolt and the top clamp-fitted stop serve to stabilize the first panel of the flap panel unit in this configuration. The top angle stop ensures the correct positioning of the closed flap panel unit. The folding hinges connect both panels of the flap panel unit and offer a larger pivot offset in order to create space for the door closer and pull handles. All the other folding panels are equipped with standard hinges and roller carriers.

### Type Cp 1

### Product description

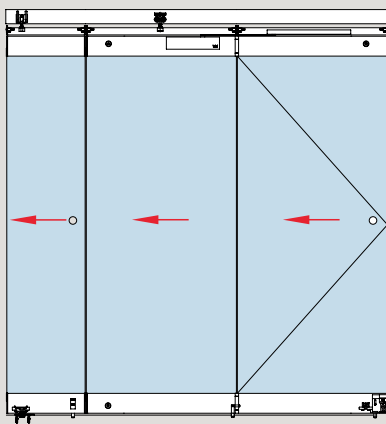

- 1 basic panel (narrow)
- 1 dual panel assembly with dormakaba TS93 G cam-action door closer

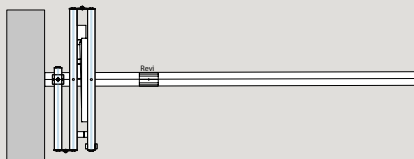
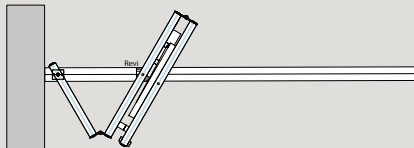
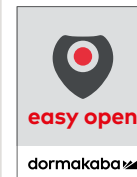

### Type Cp1 dual assembly (bi-parting)

### Product description

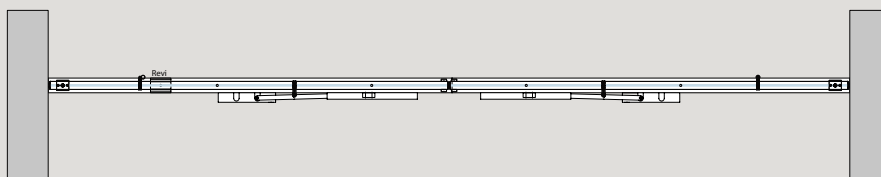

- Left:**
- 1 basic panel (narrow)
  - 1 dual panel assembly with dormakaba TS93 G cam-action door closer

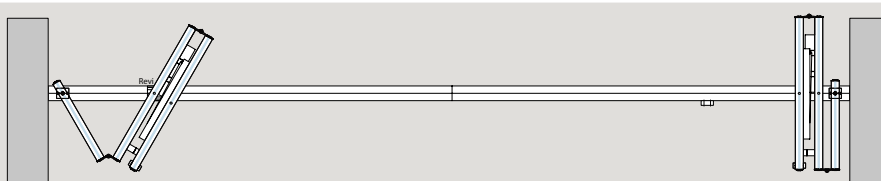

- Right:**
- 1 basic panel (narrow)
  - 1 dual panel assembly with dormakaba TS93 G cam-action door closer

**Type Cp 2**

**Product description**

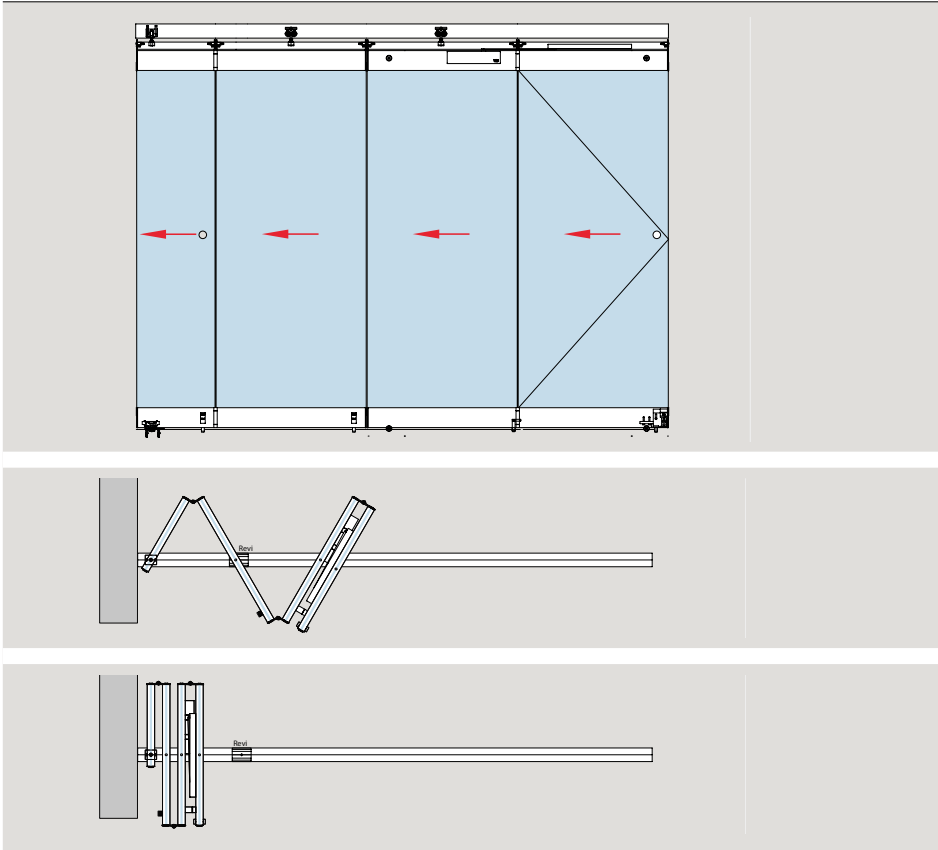

- 1 basic panel (narrow)
- 1 – 5 centre panels
- 1 dual panel assembly with dormakaba TS93 G cam-action door closer

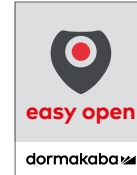

**Type Cp2, dual assembly (bi-parting)**

**Product description**

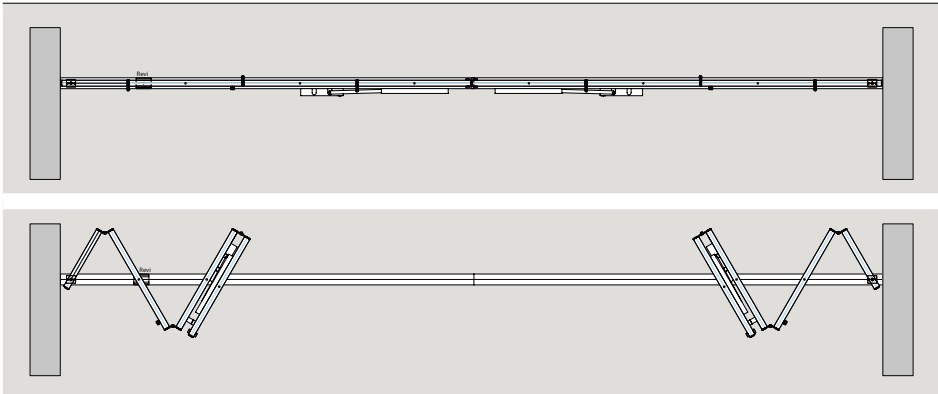

- Left:**
- 1 basic panel (narrow)
  - 1 – 5 centre panels
  - 1 dual panel assembly with dormakaba TS93 G cam-action door closer

- Right:**
- 1 basic panel (narrow)
  - 1 – 5 centre panels
  - 1 dual panel assembly with dormakaba TS93 G cam-action door closer

**dormakaba TS 93 technical data and features**

Spring strength/Door closer size	EN 2 – 5	EN 5 – 7
Adjustable closing force	Adjustable screw	Adjustable screw
Adjustable closing speed	Adjustable valve	Adjustable valve
Non-handed	Yes	Yes
Adjustable latching action	Adjustable valve	Adjustable valve
Adjustable backcheck	80° – 120°	80° – 120°
Adjustable hold-open	75° – 150°	75° – 150°
Weight	3.5 kg	5.2 kg
Length	275 mm	285 mm
Installation depth	53 mm	62 mm
Height	60 mm	71 mm



## Accessories

# Lower floor bushings

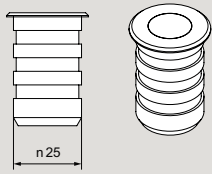
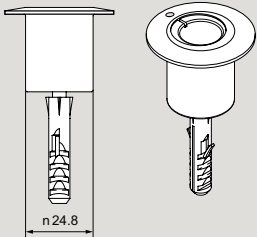
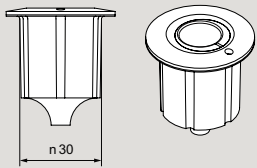
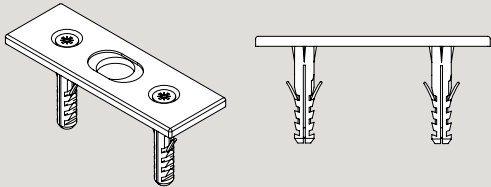
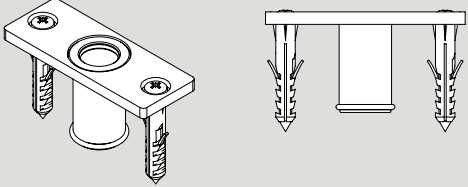
	Produktbeschreibung	EAN-Code	Art.-Nr.
	<b>Bottom bushing</b> with plug	84002800150	<b>15.193</b>
	<b>Eccentric bush</b> screwed	81520200250	<b>15.194</b>
	<b>HSW ES Eccentric locking bush</b> with glueable insert	84002800150	<b>40.277</b>
	<b>Strike plate</b> screwed	81509700150	<b>05.190</b>
	<b>HSW ES Strike plate with lifting bush</b> complete	84075400150	<b>40.358</b>



# **General Information**

# Measuring up

## Important site measurements

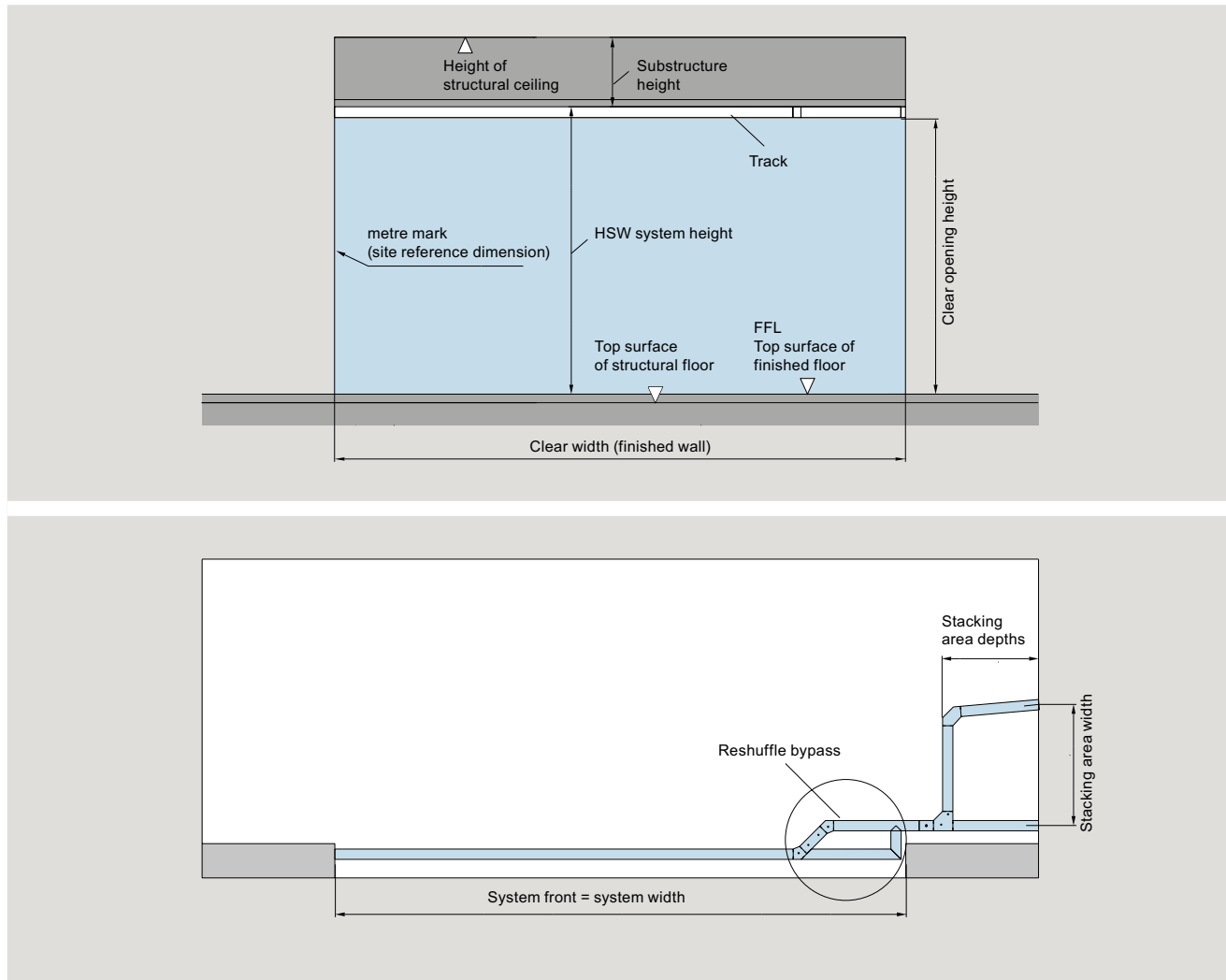

### Ground conditions for the installation of HSW/FSW systems

For the installation of a HSW system, in addition to a horizontally aligned, and sufficiently load-bearing substructure, the condition of the floor as the lower connection point must also be taken into account.

#### In particular, the following applies here:

- the floor area must be designed in such a way that striking plates or the defined floor floor bushings can be accommodated and mounted. (the course of a HSW axis on a parting line or any other floor not designed to receive the to accommodate the bottom closure elements must be avoided).
- the floor itself should ideally be horizontal and level.
- the floor surface texture should not be too rough and coarse.
- if there is a floor slope, the installation can possibly still be realized under certain circumstances if:
  - a) it is basically and exclusively an HSW installation with door rails (no FSW, no framed HSW design).
  - b) the slope is relatively uniform and does not show large fluctuations; depending on the slope, it may be necessary, in addition to the sloped the bottom rails of the door to the glass, it may be necessary to stagger the height of the glass.
  - c) the parking position of the wings is provided in any case at the lowest point
- in the case of certain floor courses, such as a wavy floor course with constantly changing and/or a rise of the ground from the central area to both sides, a HSW is required.

HSW installation may not be possible or may only be possible after the ground has been leveled or other constructive measures have been taken.\* In the case of the points mentioned here, as well as possibly other factors occurring on the construction site, the installer

may have to use a suitable profile in the closure. profile in the closure or sealing axis of the HSW/FSW, if necessary, in order to sealing axis of the HSW/FSW, if necessary, in order to allow the function of the system.

## Notes on portal systems

### Maintenance recommendation for high-frequency HSW systems

Horizontal sliding walls with glass panels have been developed in order to provide retail outlets with generous and enticing frontages – entrances that offer easy accessibility and an inviting appearance for customers. When the frontages are closed, they can double up as expansive shop windows.

In cases where double-action sliding panels are used for main entrances as a portal system (i. e. in shopping malls or as similar operated HSW systems) they are submitted to very high daily traffic volumes and usage frequency rates.

The door closers and pivot bearings used by DORMA-Glas have been successfully tested in accordance with the requirements of EN 1154. EN 1154 specifies 500000 test cycles for manually operated closing devices.

High-frequency portal systems such as the above can reach this number of cycles after just a few months. Consequently, DORMA-Glas recommends that such units be regularly maintained. The higher the usage levels, the more frequently the equipment should be serviced by either the installation firm or a similarly specialized fitter.

In addition to any door closer that may be fitted, a suitable opening limitre (to be provided on site) will also be required as protection for single-action and double-action sliding panels. In the case particularly of public and highly frequented entrance systems, door closers are unsuitable as opening limitres as any excess pressure applied to doors will lead to high stress forces being applied at the sweep maximum.

# Finishes

## Deviations in colour due to production procedures cannot be totally excluded.

HSW systems with surface finishes 700 and 701 contain different component materials.

In the case of FSW (folding sliding walls) systems, for example, the folding hinges are always of aluminium, while the standard surface finish for brush profiles and end covers is black anodised (E6/C35). These various components can also optionally be anodised or powder-

coated so that they resemble the ordered surface finish. The standard surface of upper locking units and upper locking bolts is a powder-coated RAL colour.

Typical manufacturing flow marks appear when anodising the milled area of the track rail modules. As an alternative to the anodized EV 1 surface finish, we therefore offer modules and track rails in all lengths in a powder-coated version similar to EV 1 for visual reasons.

Finishes			
Aluminium, mill finish and anodized	DORMA-Glas No.	Sim. to Eloxal I	Sim. to Eloxal II
AL mill finish	100		
AL anodized, EV1, sanded, matte (for profiles: stained, matte)	101	EV1	C 0
AL anodized, similar stainless steel, polished, matte	107		
AL anodized, similar stainless steel, satin (for profile material) (similar Anodizing II C 31)	113		C 31
AL anodized, special	199		

Aluminium, powder coated	DORMA-Glas No.	Sim. to HEWI-No.	Sim. to RAL
AL powder coated, Traffic white, smooth, glossy (sim. RAL 9016)	300	99	9016
AL powder coated, Special color (Standard powder according to the corresponding overview on our website. A price surcharge is possible for special colors outside the color range specified there.)	399		

Stainless steel, various finish treatments	DORMA-Glas No.
Stainless steel, satin (compatible with 750)	700

Finishes HSW EASY Safe	
Aluminium, mill finish and anodized	DORMA-Glas No.
AL mill finish	100
AL anodized, Silver, satin, matte (compatible with finish 114)	150
AL anodized, similar stainless steel, satin	157
AL anodized, special	199

Aluminium, powder coated	DORMA-Glas No.
AL powder coated, Jet black, smooth, matte (sim. RAL 9005)	304
AL powder coated, similar anodized EV1, smooth, matte	318
AL powder coated, Traffic white, smooth, semi gloss (sim. RAL 9016)	350
AL powder coated, Special color, high weather resistant	398
AL powder coated, Special color (Standard powder according to the corresponding overview on our website. A price surcharge is possible for special colors outside the color range specified there.)	399

Stainless steel, various finish treatments	DORMA-Glas No.
Stainless steel, satin (compatible with 750)	700

# Safety-related information

## Important safety-related information for the mounting and use of DORMA-Glas glass fittings.

(Follow these instructions in addition to the mounting and operating instructions in order to avoid damage of product and damage to person or property.)

**Important:** All users have to be informed about relevant points mentioned in these safety-related information and the mounting and operating instructions!

### General information

1. DORMA-Glas recommends the use of TSG-H (heat-stored tempered safety glass) according to DIN EN 12150-1.
2. DORMA-Glas glass fittings are only conditionally suitable for outdoor installation.
3. DORMA-Glas glass fittings are not suitable for rooms where chemicals (e.g. chlorine) are used, e.g. swimming pools, saunas and brine baths.



4. Sliding panels must not be moved faster than at walking speed and must be stopped by hand before reaching the end position will be.
5. Pivoting panels must not be thrown too hard. If there is a risk of over-turning, this must be prevented by a door stop.

### Mounting

1. Only properly qualified and specially trained staff is authorised to mount DORMA-Glas glass fittings.
2. Never use glass with conchoidal fractures and/or damaged edges.
3. Due to crushing hazards – among others in the area of the secondary closing edge – and possible injury caused by breakage of glass during mounting, corresponding protective clothing (especially gloves and protective goggles) is required.
4. Clean clamping area with fat solvent (standard commercial cleaning agent) before mounting the glass fitting.
5. Never use clamping shoes on structured glass surfaces (except on satined glass) or glass of heavily varying thickness unless with a corresponding levelling layer.
6. Never use clamping shoes on self-cleaning coatings.
7. When adjusting glass elements, always stick to the required clearance for the respective fitting. Adjust clearance so that the glass does not touch hard components such as glass, metal or concrete.
8. Make sure not to use excessive force when installing the glass (avoid local stress resulting from very tight screws).

### Maintenance

Check fittings at regular intervals for proper positioning and smooth running and door for correct adjustment. Especially highly-frequented door systems require inspection by properly qualified staff (specialised companies or installation firms). Immediately replace damaged glass elements (no glass flaking and/or conchoidal fractures)!

### General care instructions

The surface finishes of the fittings are not maintenance-free and should be cleaned according to their material and design.

- For metallic surfaces (anodised finishes, stainless steel) please use appropriate cleaning agents without abrasive additives only.
- For varnished surfaces please use appropriate solvent-free cleaning agents only.
- Brass surfaces (without surface protection) have to be treated with an appropriate maintenance agent on occasion, to avoid tarnishing.

**For practical planning, please use our drawings DORMA-Glas "The Detail".**

The printed colours indicating the surface finishes are not 100 % true, but do provide a useful guide. Statements made with regard to the nature or use of the products are for the purposes of descriptions. Assent with regard to the existence of particular properties or particular uses always requires special written agreement. Pictures may show special designs which are different to the standard scope of delivery.

Subject to change without notice.

# Moving Details.